

1.1	1
1.2	1
1.3	1
2.1	2
2.2	2
2.3	2
2.4	2
2.5	2
2.6	3
2.7	3
2.8	3
2.9	3
2.10	3
3.1	4
3.2	4
4.1	11
4.2	11
4.3	11
4.4	11
4.5	12
4.6	13
4.7	13
4.8	14
4.9	14
4.10	14
4.11	15
4.12	15
4.13	16
4.14	16
4.15	16
4.16	17
4.17	18
4.18	18
4.19	18
4.20 PT	18
4.21	18

5.1	19
5.2	21
5.3	22
5.4	22

概述

1.1

1.2

1.3

2 技术参数

2.1

2.2

2.3

2.4

2.5

2.6

27

90.000
X.05 +

0

3 结构

3.1



3.2

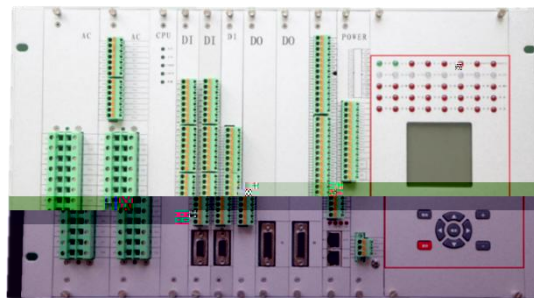

3.2.1.1



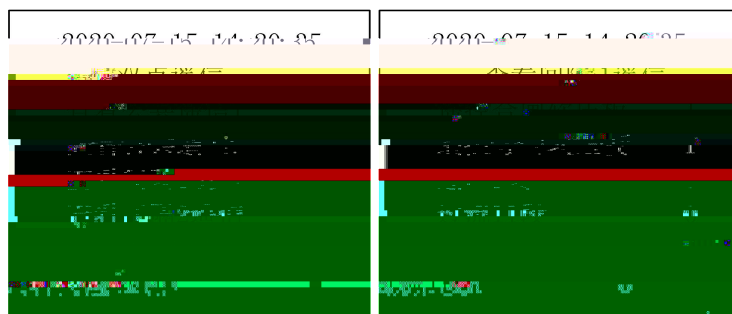
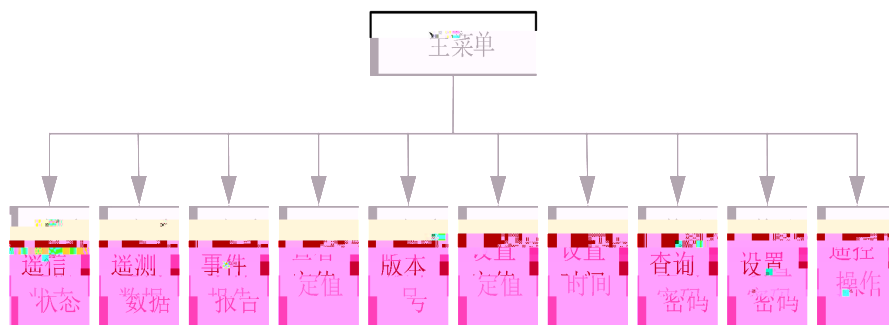

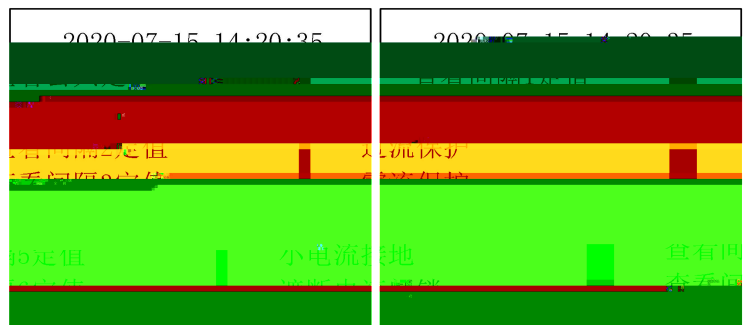
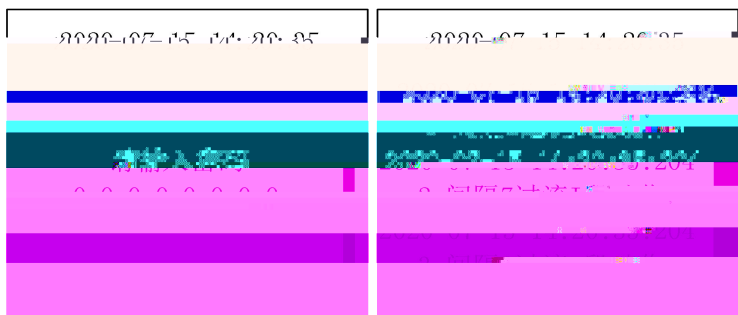
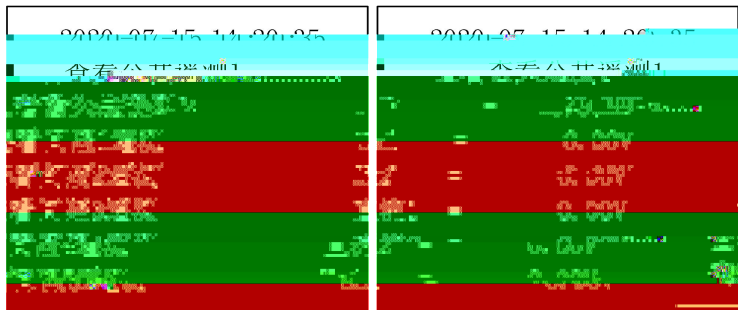

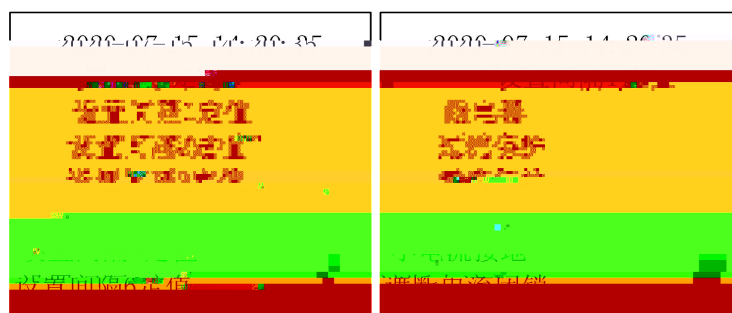
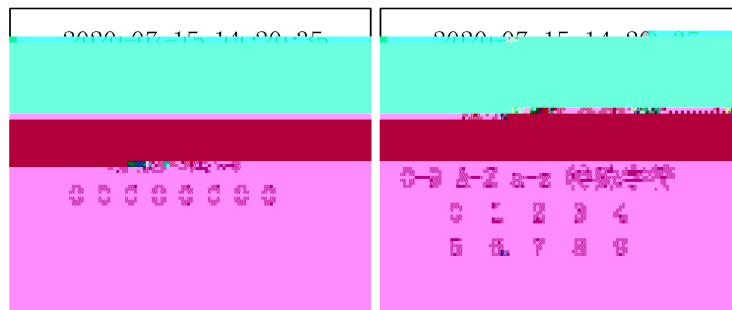
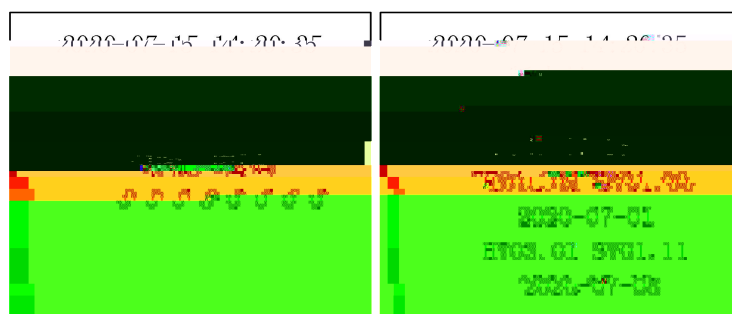
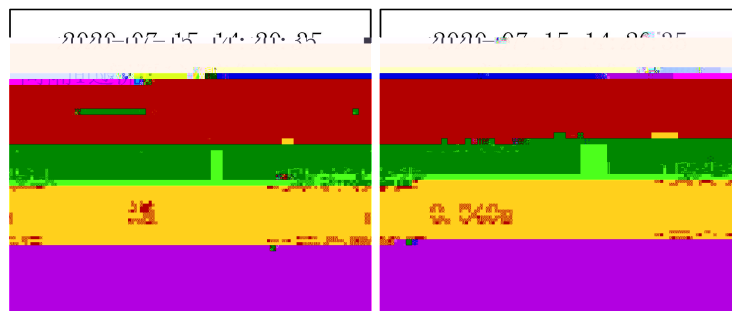

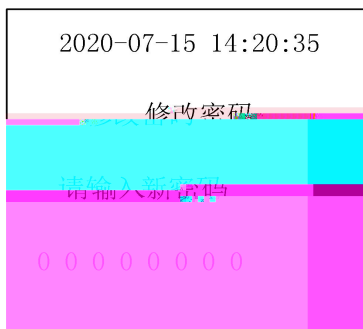
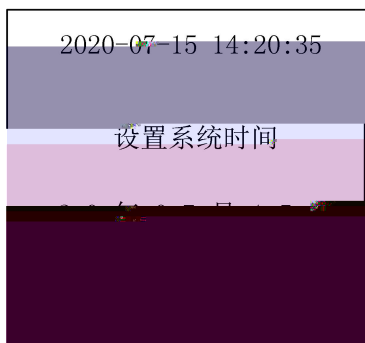
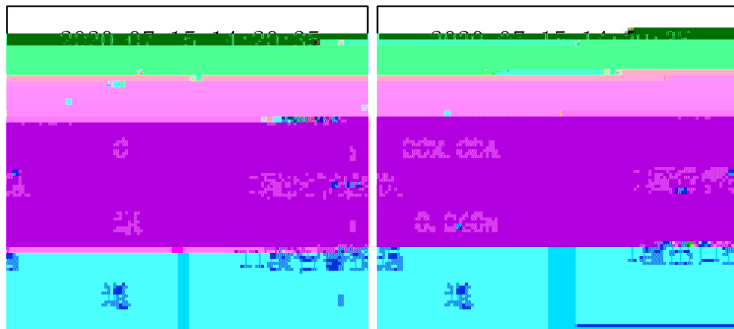

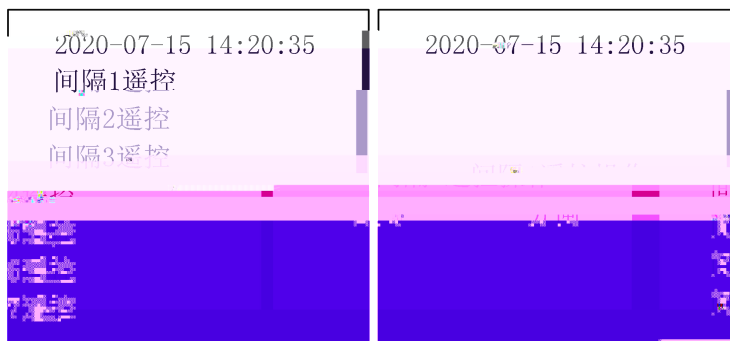
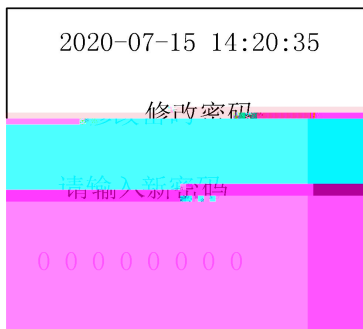

4 功能逻辑

4.1

4.2

4.3

4.4

4.8

4.9

4.10

4.13

4.16

4.17

4.18

4.19

4.20 PT

4.21

5 终端现场安装与调试

5.1

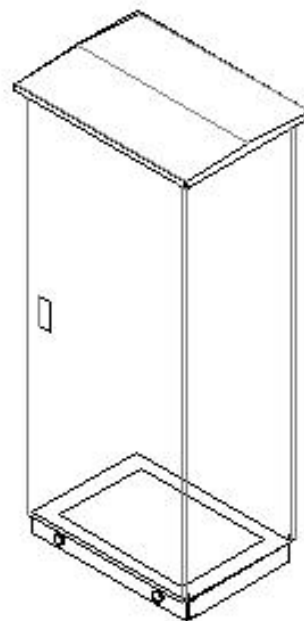
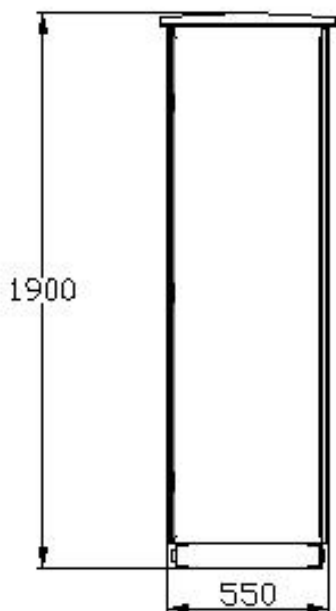
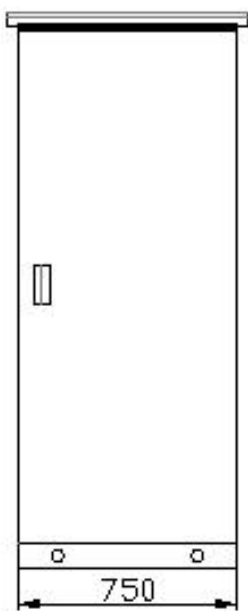
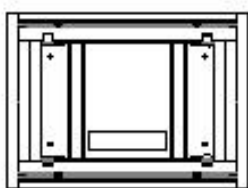

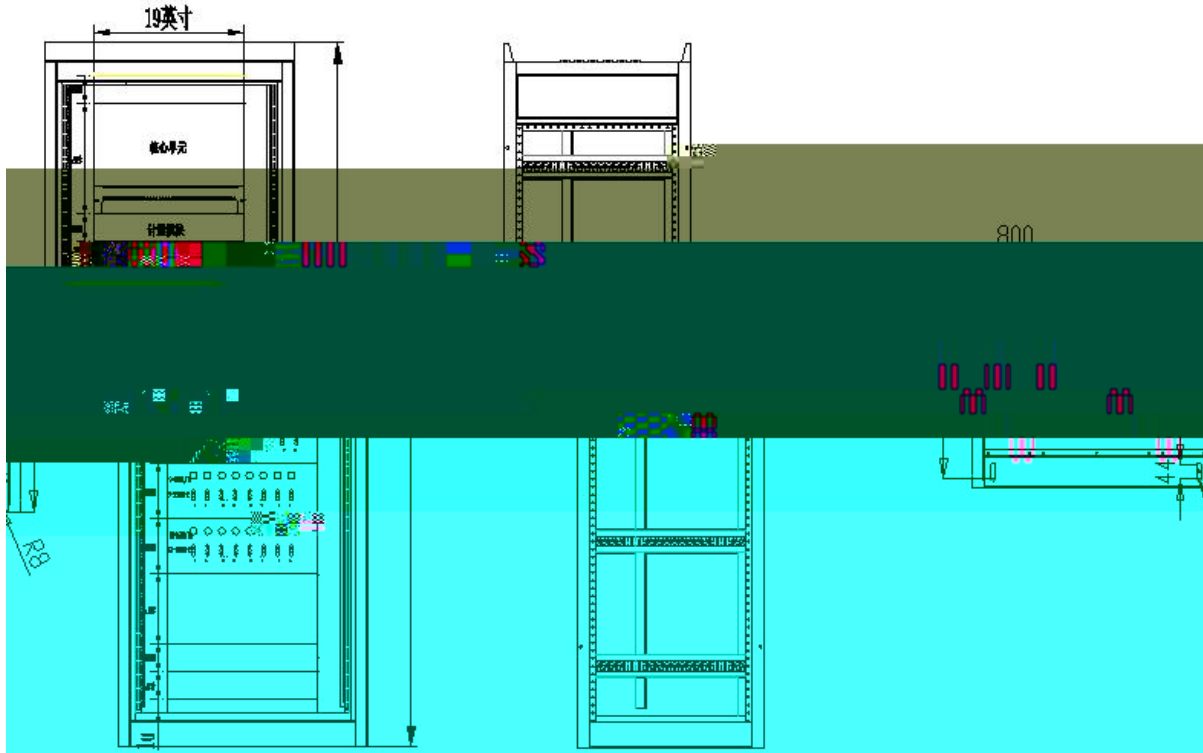

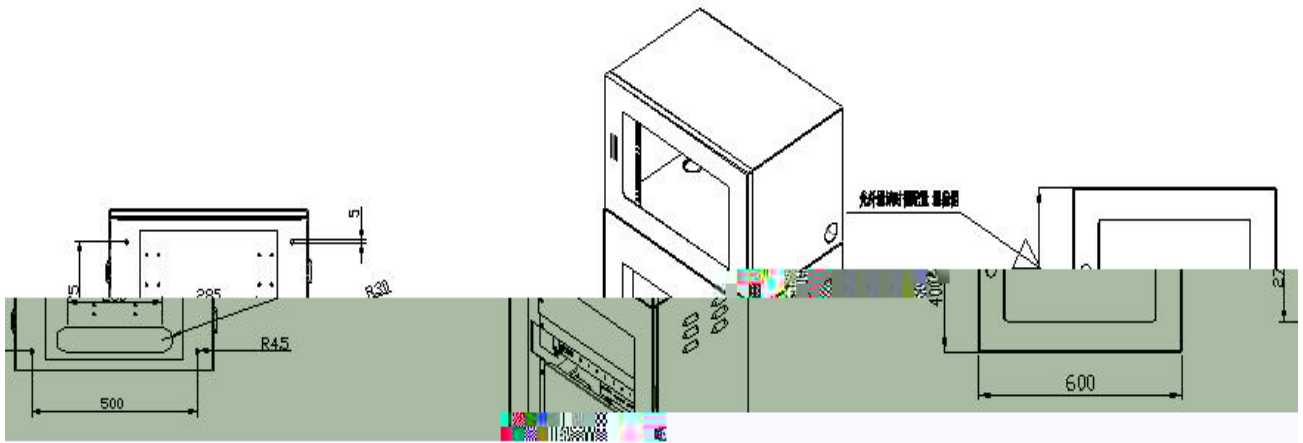

5.2

5.3

5.4



石家庄科林电气股份有限公司



地址：石家庄市红旗大街南降壁路段

Address: Nanjiangbi, Hongqi Street, Shijiazhuang City



400-0311-128

电话/Tel: 0086-311-85231078、85231088

传真/Fax: 0086-311-85231087

Http://www.Kechina.com