



股票简称：科林电气
股票代码：603050

7kW /

(32A)

V1.1





V1.0	2022-06-29	
V1.1	2022-08-17	





	
1	
2	7KW
2.1		
2.2		
2.3		
2.4		
3	
3.1		
3.2	" "	
4	
5	
6	0
7	





1

2



3

4

1

7kW

2 7kW

2.1

7kW

220V

32A

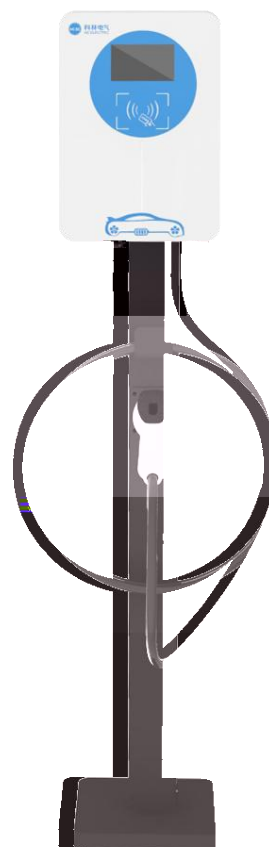
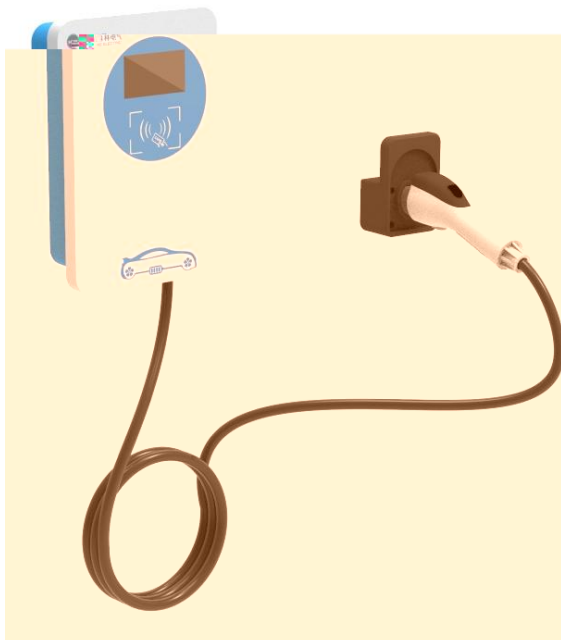

2.2

GB/T 20234.1

1

GB/T 20234.2

2

2.3

2.0

2.4

220V \pm 15%

50 \pm 1Hz

220V \pm 15%

50 \pm 1Hz

32A

-25 +55

-25 +55

5% 95%

IP55

6kg

245*350*110(* *) mm

3

2

3.1

IC

“ ” 3-1



3-1

“ ” “ ” “ ” “ ”

3-2

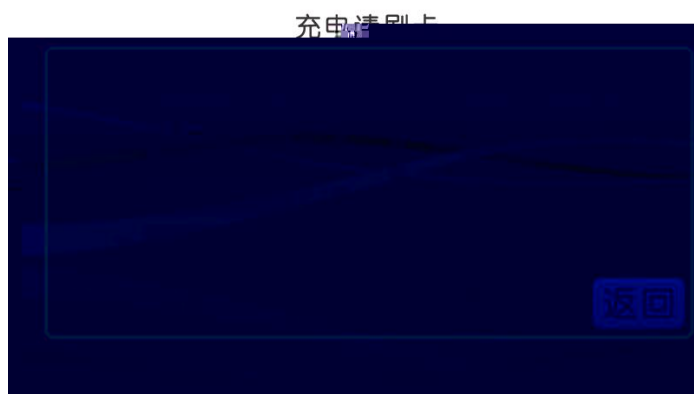

3-2

“ ” /
“ ” “ ”
IC “
“ 3-3

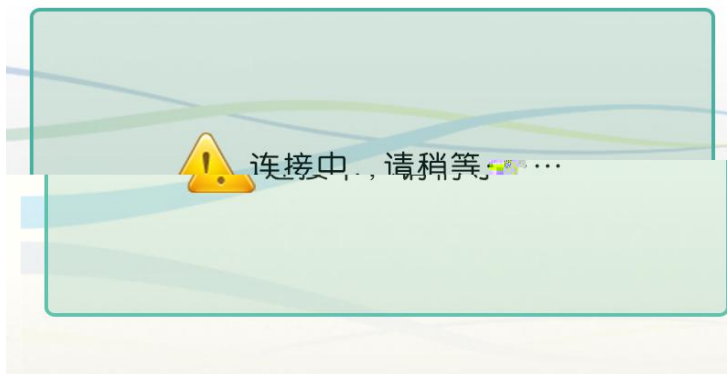

3-3

“ ”

3-4

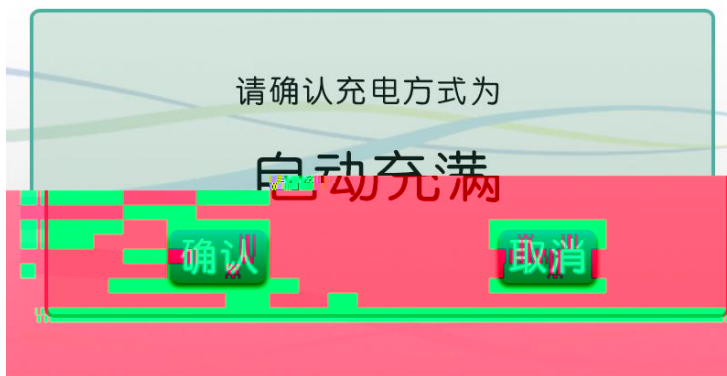

3-4

“ ” “ ”

“ ” “ ”

3-5



科林中... 系统... 的... 设计... 的... 设计... 的... 设计...



3-9

3-7 3-8

3.2

" "

" " " "

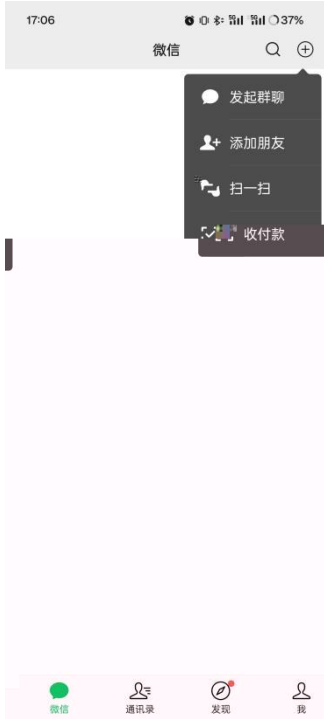

"

B

" 2 "

"

"

"

"

"

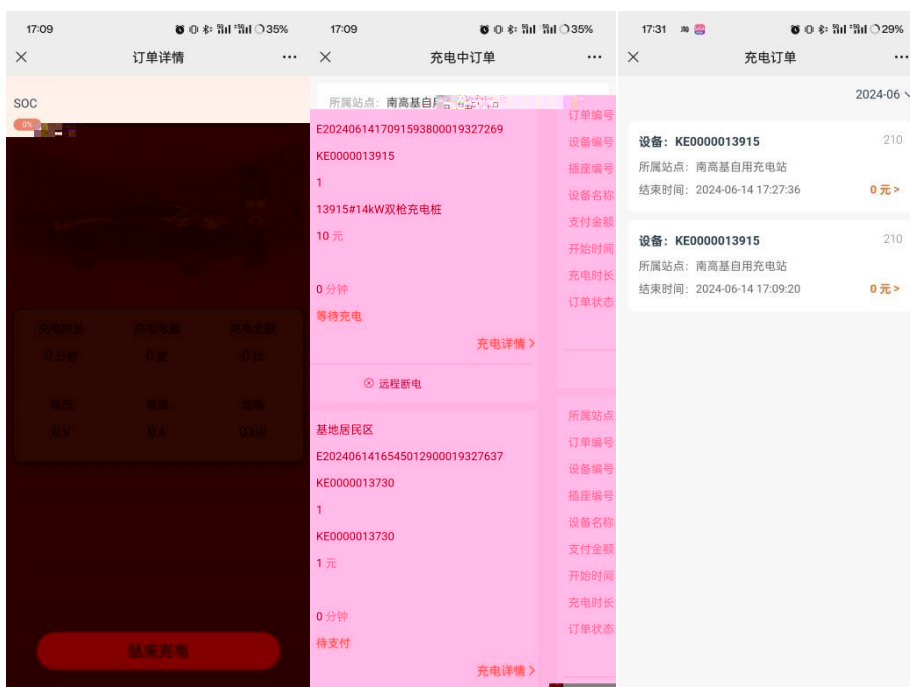
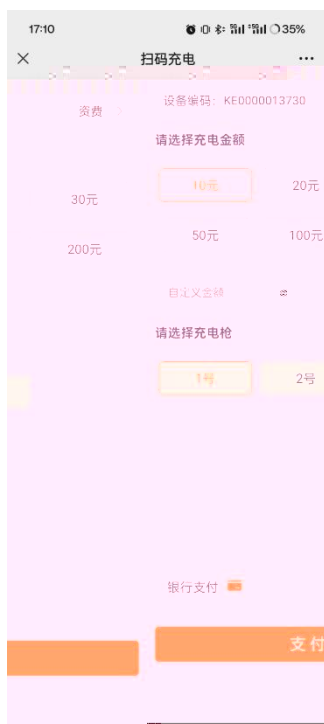

" "

4

1

7kW

220V

T20

2

1

2

1

2

M6*60

1

2

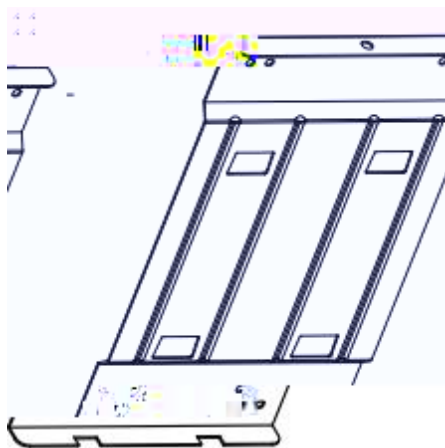

1

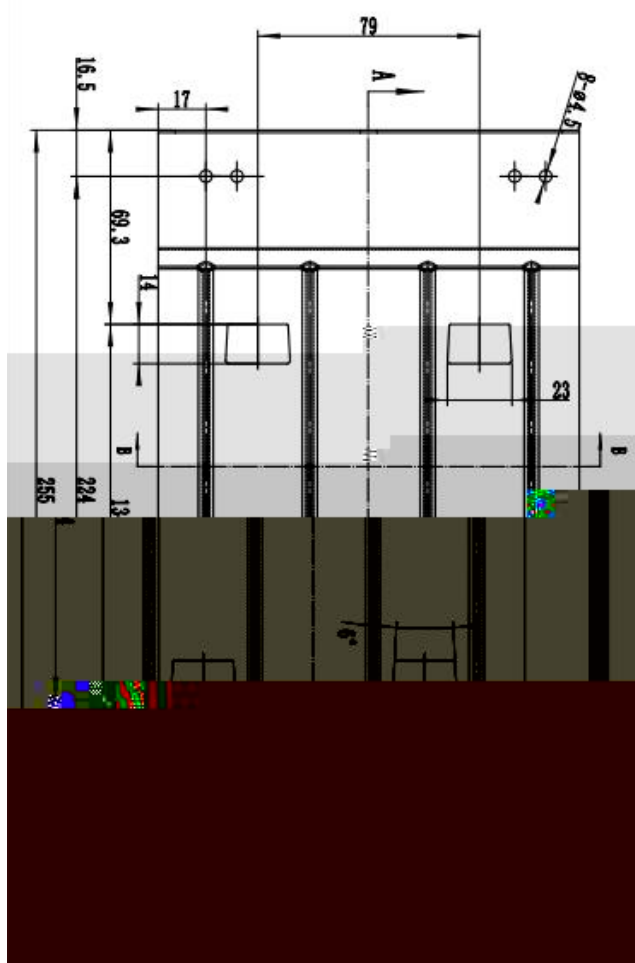

1

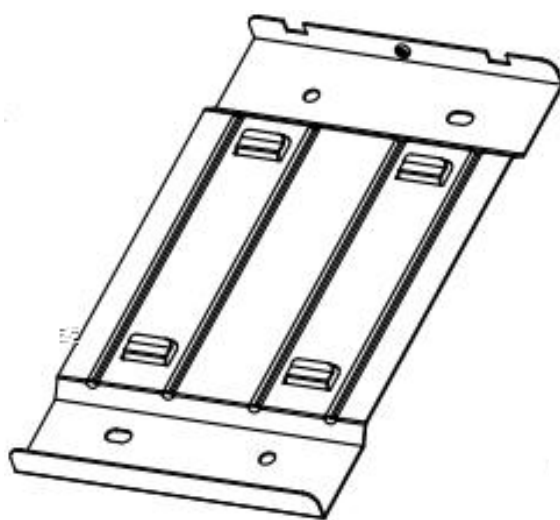

2

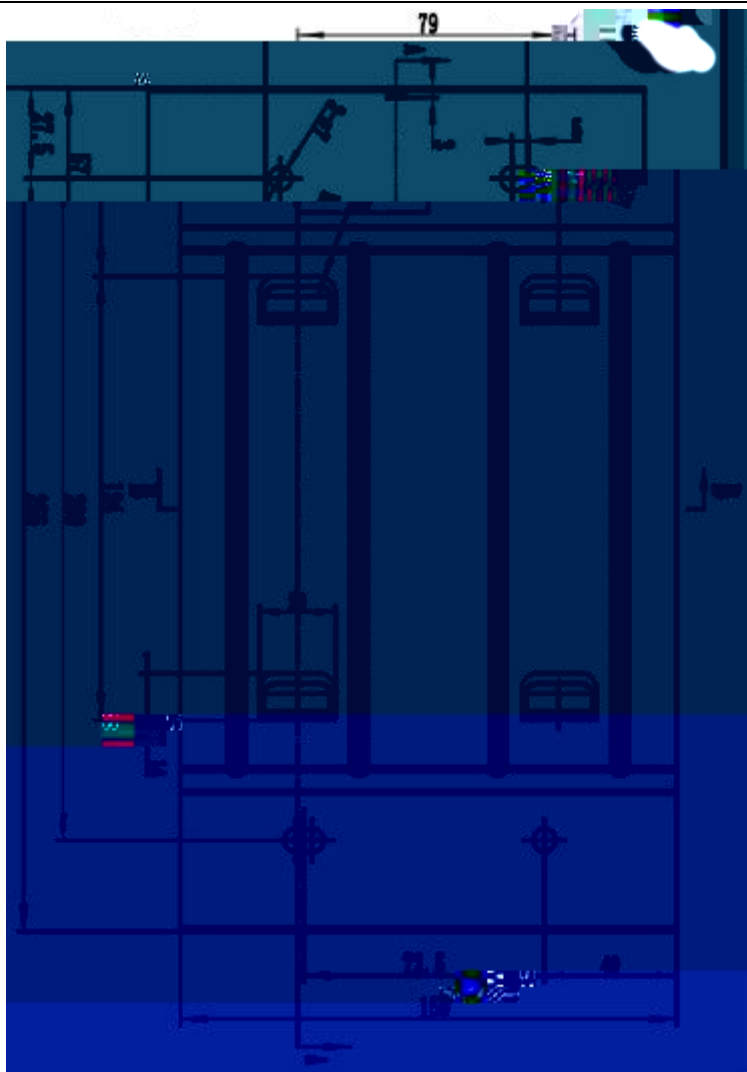

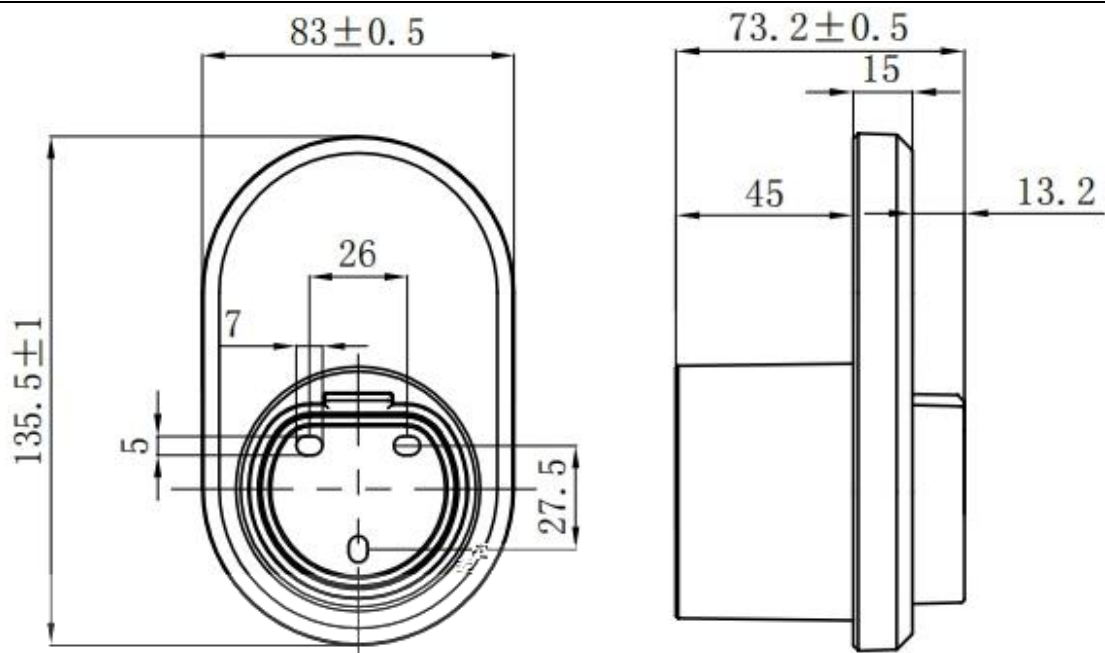

450*200*450

* *

M10*80

75*35mm

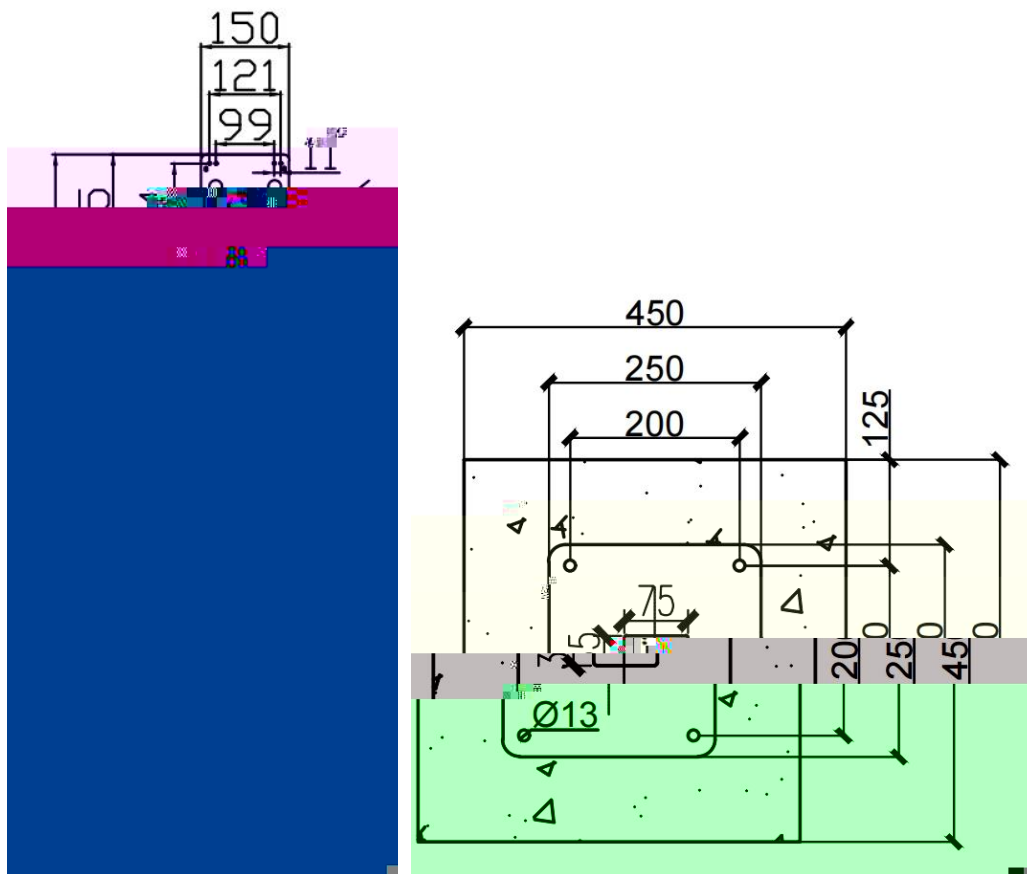

3

1 2 3 L N PE

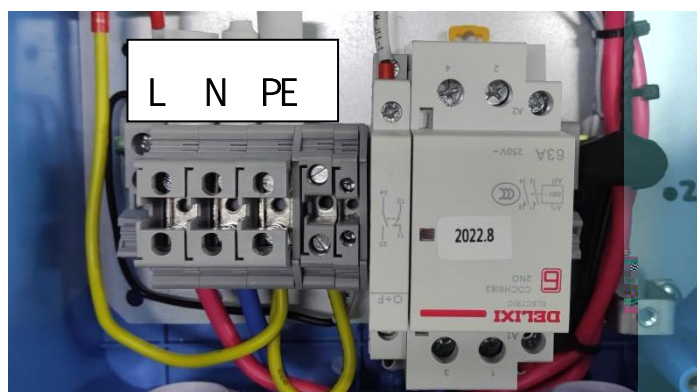

4

32A

63A

50A- - 30mA

ZR-YJV-3*6





/

7

7.1

7.2

7.3



7)

8)

9)

10)

5

,



